

AGO45L

PRODUCT GUIDE



Wheel Aligners

Car 2 Wheel Optical/Laser Aligner (Tracking Gauges)

A British hand-made Wheel Aligner that's cheaper than its mass produced Chinese competitors.

The AGO45L is our entry level unit. It's well priced and seriously well made.

Its a simple to use 2 wheel, single axle wheel alignment gauge. It has one laser and a reflective mirror that makes measuring the steer axle a quick breeze.

It does what it does, and it does it efficiently. One axle at a time. 12 inch to 24 inch rims. It doesn't break. It doesn't scratch alloys, and it won't break the bank.

Comes with:

- 2 x Wheel Alignment Gauges
- 1 x Vertical wall mounted hanger for easy storage
- 1 x Integrated Charger
- 3 Year Limited Warranty (1 year warranty on accessories)

Accessories include:

- 1 x Standard Steering Wheel Clamp

Set-up and installation:

- User manual for step-by-step guide
- Unlimited remote support

PRODUCT SPECIFICATIONS**2 x Optical/Laser Wheel Alignment Gauges**

Double powder coated gloss Jet Black (RAL 9005) and gloss Zinc Yellow (RAL 1018), the laser tube is hard wearing leatherette textured Jet Black (RAL 9005)



1 x Wall Bracket



1 x Toe Scale

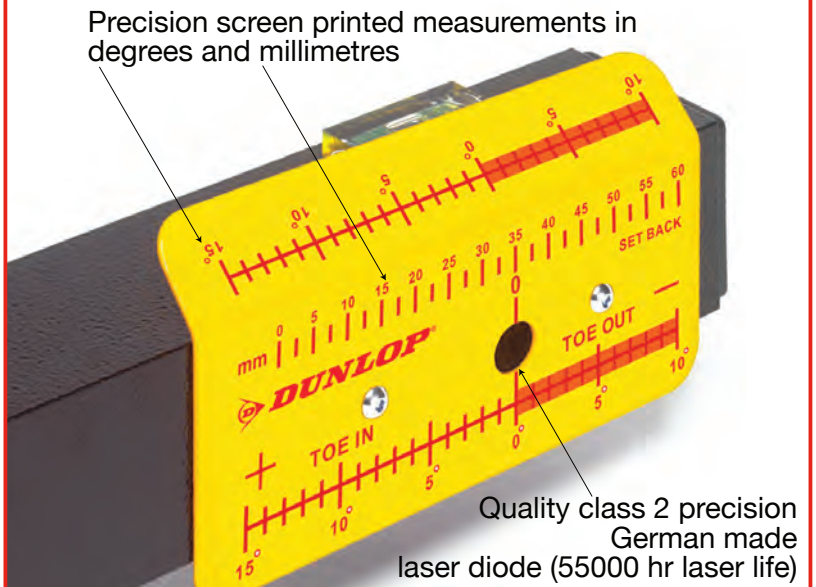

1 x Mirror



6 x Precision milled spring loaded Rim Buttons

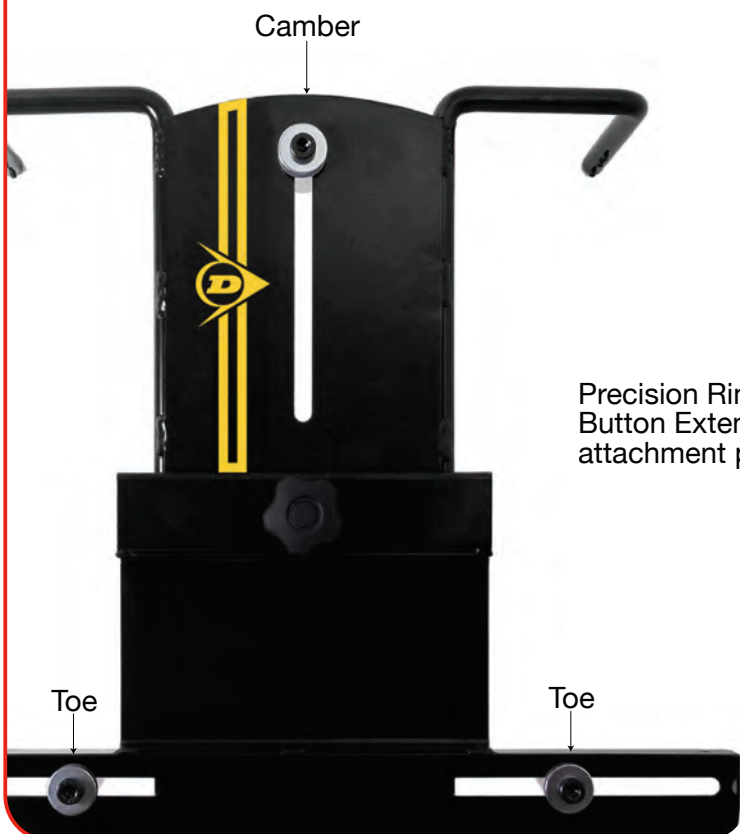

Precision Rim Button Extension attachment point



Rim Button Extensions (sold separately)

2 x Heavy Duty Dished Turnplates

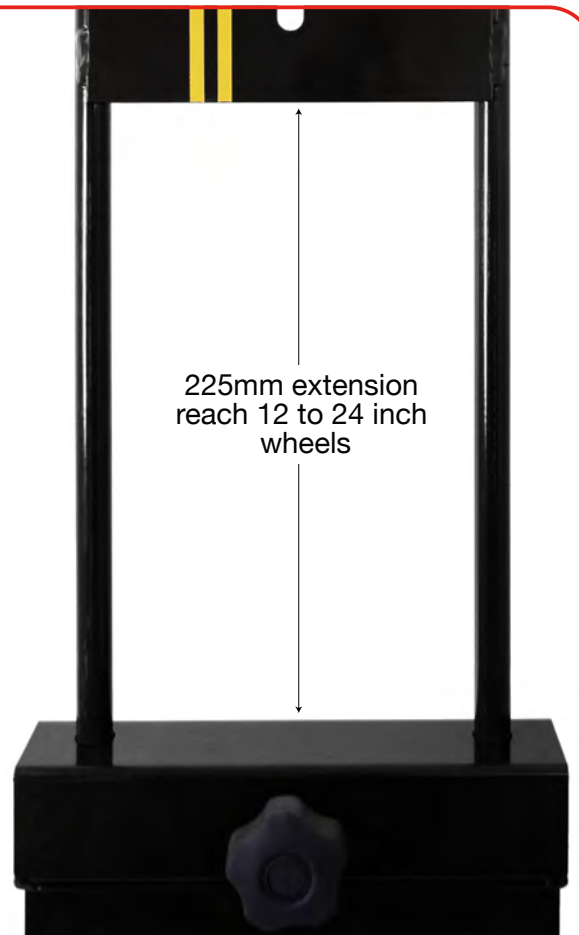
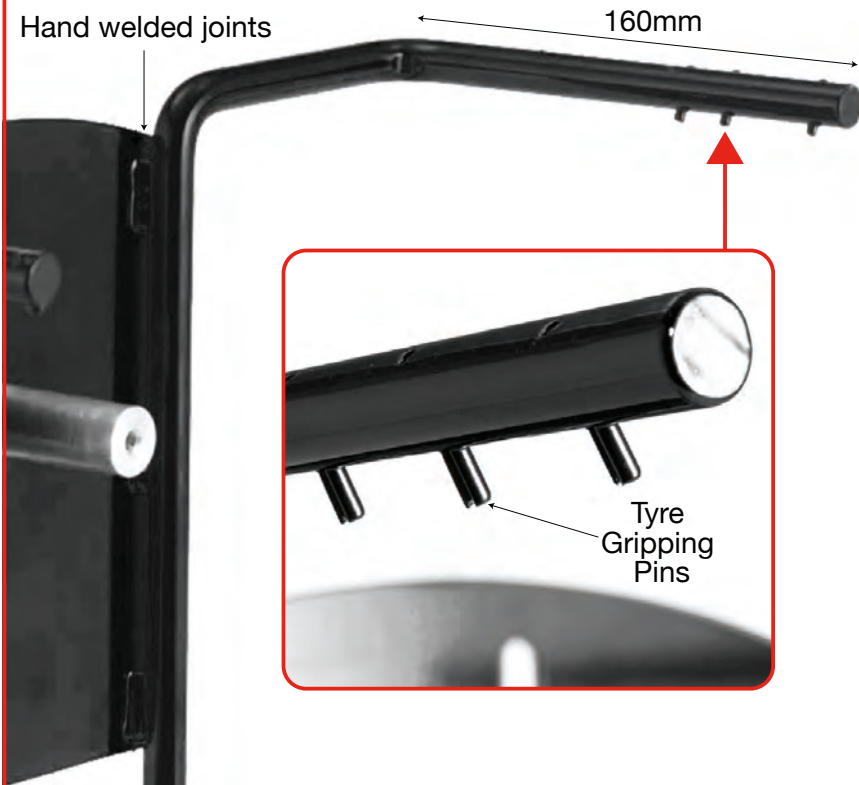

1 x Standard Steering Wheel Clamp



Weight (cardboard box): 17kg

