



Super Automatic tyre changer with technology **"SENZA LEVA" - CONTACTLESS**

Innovative super automatic tyre changer for all wheels from 13" to 28"



AQUILA RAPAX

AQUILA RAPAX is a new automatic tyre changer, “without lever” working technology for car, SUV and commercial vehicle wheels of up to 28”.

tyre mounting and demounting tool based on the operation technology of **AQUILA TORNADO**, whereby the rim is never touched and stress on the tyre bead is reduced.

Tool with manual rotation to **speed up work operations**.

Technical features: wheel lifter for uplifting the wheel from the ground to working position and the other way round, the bead-breaking system works with **two specular bead-breaker discs** featuring controlled penetration control, automatic wheel clamping with effective, fast and simple pneumatic system. Multifunctional control panel providing high comfort and convenience of use, combined with **effective performance**.

All this allows for higher operational speed with no risk at all for the operator and the rims/tires - even when performing the hardest tasks. **Increased ease of use and greater flexibility** with all types of wheels are also among the key benefits of the system. This is why the equipment can be effectively used to the maximum of its working potential.



1. Zero effort wheel lifter
2. Automatic - Pneumatic Clamping System
3. New mounting and demounting tool
4. Control panel
5. Bead breaker unit
6. Emergency hook for mounting the first bead breaker
7. Press Mate
8. Pedal unit

1 Zero effort wheel lifter

Front lifter with **full upwards and downwards movement**.

It allows the operator to move the wheel on the tyre changer without any effort and **without changing working position**.



2 Automatic - Pneumatic Clamping System

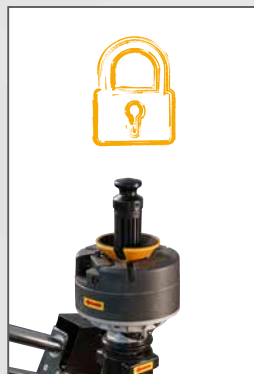

New wheel-clamping system for quick operation and flexible with all wheel types.

The pedal - when pressed - **releases** the clamping system turntable centring handle.

In the rest position, the clamping **system on the turntable centring handle** is normally active.



The pedal is used over the wheel preparation and turntable clamping phase, as well as **to release the wheel once the operation has been completed** - this feature is already available with Raptor.

AQUILA RAPAX

3 New mounting and demounting tool

The radial positioning of this innovative tool is carried out by using the controls on the panel.

Tool with manual rotation to speed up work operations. By performing the rotation, the tool will remain automatically in the correct radial position over the two phases. The part used for disassembling is equipped with a patented spring system to facilitate the entry of the bead breaker disc between rim without any risk for the tyre itself.

DEMOUNTING



MANUAL ROTATION OF THE TOOL ALLOWS THE OPERATOR TO SWITCH QUICKLY AND EASILY FROM DEMOUNTING TO MOUNTING MODE



LOWER BEAD DEMOUNT OPERATION WITH THE ASSISTANCE OF THE LOWER BEAD BREAKER DISC

Quick demounting procedure with bead breaker disc.

Quick procedure for demounting the lower bead - highly recommended for hard sides.



4 Control panel



Complete and intuitive

Multifunctional control panel.

Ideal for dynamic bead breaking and for rim and tyre match mounting, thanks to the two dual control discs.

5 Bead braking unit

- **Dynamic bead braking device** with dual specular bead breaker disc. The radial positioning of the discs is made easier through an automation device preventing the operator from wrong manual positioning.
- **Controlled penetration (Patent Pending)**: precision, speed and repeatability are guaranteed by the patented bead-breaking system and perfect correspondence between the two discs.



**DRIVE WITH AN INVERTER MOTOR SYSTEM:
ON THE ROTATION PHASE THE RIGHT TORQUE AT THE RIGHT SPEED**

6 "Emergency hook"



The mounting operation is easy and very quick.

It is possible to press downwards with the tool holder arm while moving the turntable at the same time.

If the tyre is soft or with a wide shoulder, a **reclining tool can also be used** as long as it is positioned on the lower bead breaking disc.



The mounting phase of the second bead is completed by **using the bead breaker disc and the turntable rotation at the same time**, while in case of either lowered tyres or RFT tyres, the Press Mate shall be used to ensure that the tyre remains on the rim channel.

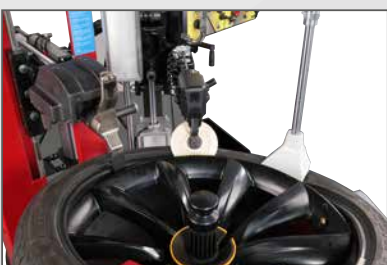

For more awkward tyres it is always important to lubricate - as with all wheel types - and use the Press Mate.

On the last phase, make sure you slightly raise the position of the disc and the Press Mate to **reduce tension and facilitate assembly**.

7 PRESS MATE - no more trouble with run-flat tyres!

- PRESS MATE with adjustable working height
- Depressor shape ideal for RFT tyres
- **Standard supplied in all versions**
- Return to working position is made easier with a spring system



Outfit

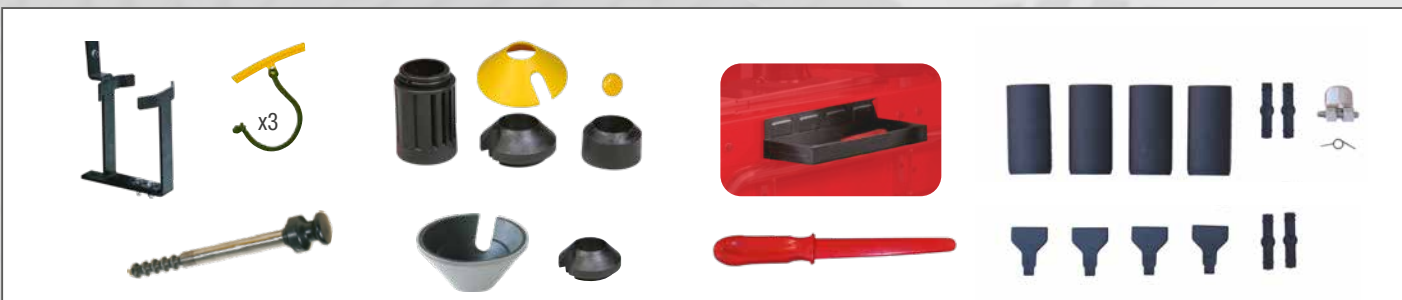

Comfort and convenience

Working height of the machine designed to obtain **perfect ergonomics** in movements with all types of wheels.
Ideal for all operators!



Recommended accessories



A. 8-11120053

Kit TI - Rapid inflation system

A. 8-11120054

Kit TI - ASME Rapid inflation system
(USA - CANADA)

B. 8-11100039

Flange for reverse rim wheels

C. 8-11100038

Universal flange for closed rims

D. 8-11100037

Pick-up rim kit

E. 8-11100120

Sliding bead pressing clamp

Technical data

wheel size range	
rim diameter	from 13" to 28"
max. tyre diameter	1200 mm (47")
maximum tyre width	15" (from the wheel bearing plane)
tyre types processed	conventional, low profile and Run Flat
turntable	
clamping	automatic - pneumatic
drive system	2-speed inverter motor
rotation torque	1100Nm
rotation speed	7-18 rpm
bead-breaker	
maximum bead-breaking range	670mm
bead-breaker stroke	540mm
bead-breaker force	7600 N
wheel loading/unloading	
operation	pneumatic
max wheel weight	85 kg
power supply	
electric 1Ph	230V-0.98 kW 50Hz/60 Hz
electric 1Ph (alternative)	110V-0.98 kW 50Hz/60 Hz
pneumatic operating pressure	8 bar (minimum)
weight	425 kg (with Press Mate and lifter)

Dimensions

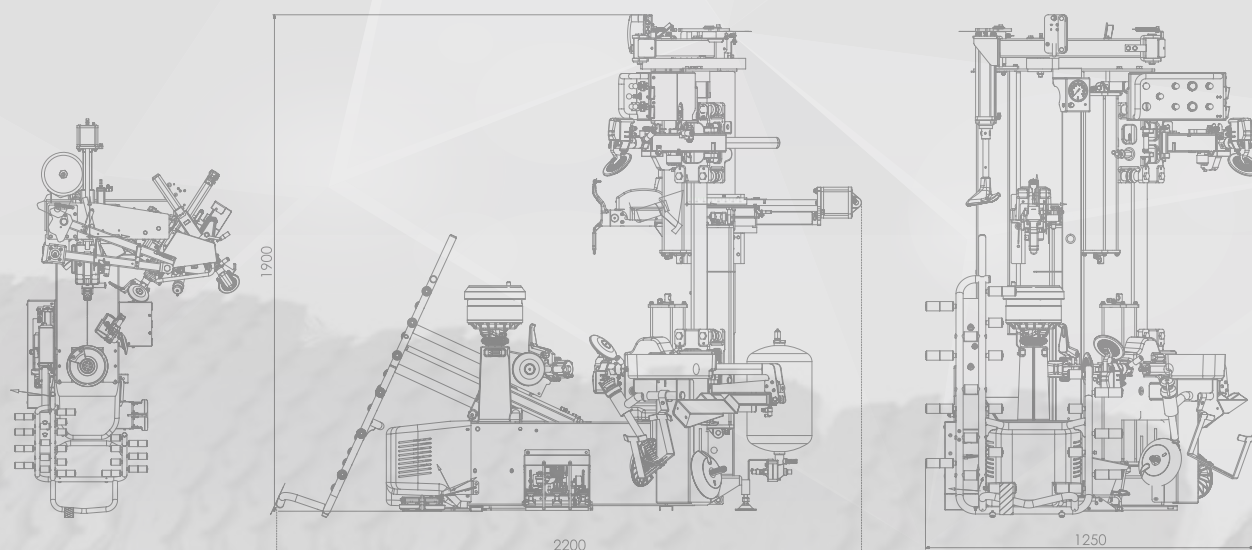

For further information, consult the complete accessories catalogue.