

ITEM	PART. No	DESCRIPTION	QT. Y
1	J405-1100000	Base	2
2	J401-1300000	Control-Box	1
3	J401-1000001	Hoses Cover	2
4	J401-1000002	Hoses Cover short	1
5	J401-1000003	Hoses Cover Base	2
6	J401-1000004	Rubber Pad	4

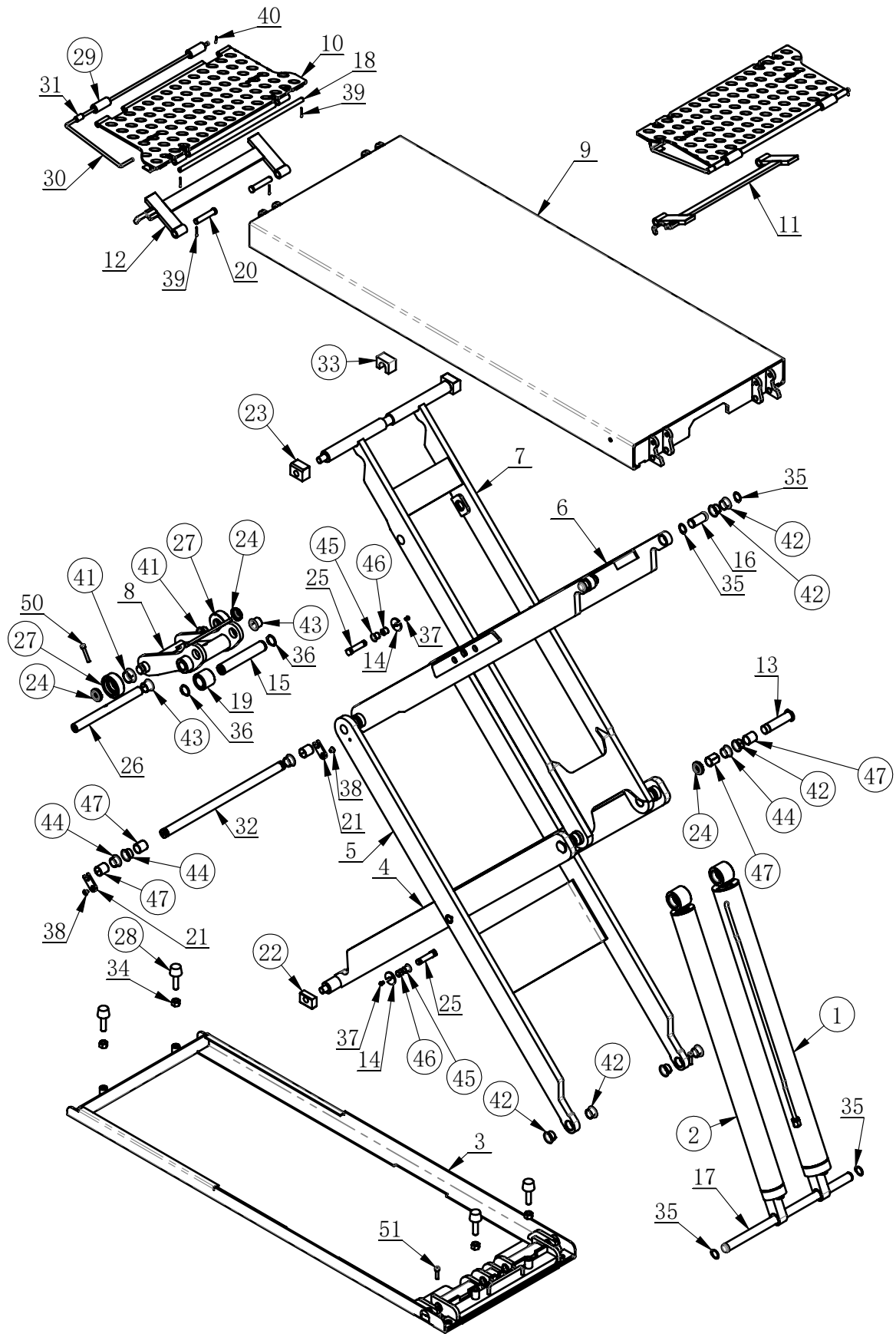

ITEM	PART. No	DESCRIPTION	QT. Y
1	J401-1110000	Master Cylinder	1
2	J401-1120000	Slave Cylinder	1
3	J404-1130000	Base	1
4	J405-1110000	Scissor Internal Bottom	1
5	J405-1120000	Scissor External Bottom	1
6	J405-1130000	Scissor External Top	1
7	J405-1140000	Scissor Internal Top	1
8	J404-1180000	Lever	1
9	J404-1190000	Platform	1
10	J404-11A0000	Flap	2
11	J401-11B0000	Support Left	1
12	J401-11C0000	Support Right	1
13	J404-1100001	Scissor Pin	2
14	J401-1100002	Fork Plate	4
15	J401-1100003	Roller Pin	1
16	J401-1100004	Platform Pin	2
17	J401-1100005	Base Pin	1
18	J401-1100006	Flap Pin	2
19	J401-1100007	Spacer	1
20	J401-1100008	Support Pin	4
21	J401-1100009	Fork Plate	2
22	J404-1100010	Base Sliding Pad	2
23	J404-1100011	Platform Sliding Pad	2
24	J401-1100012	Nut M25X1,5	4
25	J404-1100013	Scissor middle Pin	4
26	J404-1100014	Lever Pin	1
27	J401-1100015	Roller	2
28	J401-1100016	Rubber Screw	4
29	J401-1100018	Flap Roller	4
30	J401-1100019	Flap Lever	2
31	J401-1100020	Spacer	2
32	J401-1100021	Lever Pin Long	1
33	J401-1100022	Middle Sliding Pad	1
34	GB41-M14	HEXANGULAR NUT	4
35	GB894. 2-25	SHAFT ELATIC RETAINING RING B-TYPE	6
36	GB894. 2-30	SHAFT ELATIC RETAINING RING B-TYPE	2
37	GB70. 2-M6×10	INNER HEXA CYLINDRICAL ROUND HEAD SCREW	4
38	GB70. 3-M8×10	INNER COUNTERSUNK SCREW	2
39	GB91-2. 5×25	SLOTTED PIN	8
40	GB91-2. 5×16	SLOTTED PIN	2
41	SF-1-30160	Self-Lubricating Bushing	2
42	SF-1-25115	Self-Lubricating Bushing	10
43	SF-1-25215	Self-Lubricating Bushing	2
44	SF-1-25165	Self-Lubricating Bushing	6
45	SF-1-15170	Self-Lubricating Bushing	4
46	GB12613-15X17X15	Self-Lubricating Bushing	4
47	GB12613-25X28X30	Self-Lubricating Bushing	8
50	GB70. 1-M8×45	INNER HEXA CYLINDRICAL SCREW	1
51	GB70. 1-M8×30	INNER HEXA CYLINDRICAL SCREW	2

J401-1110000.

Revision A-03

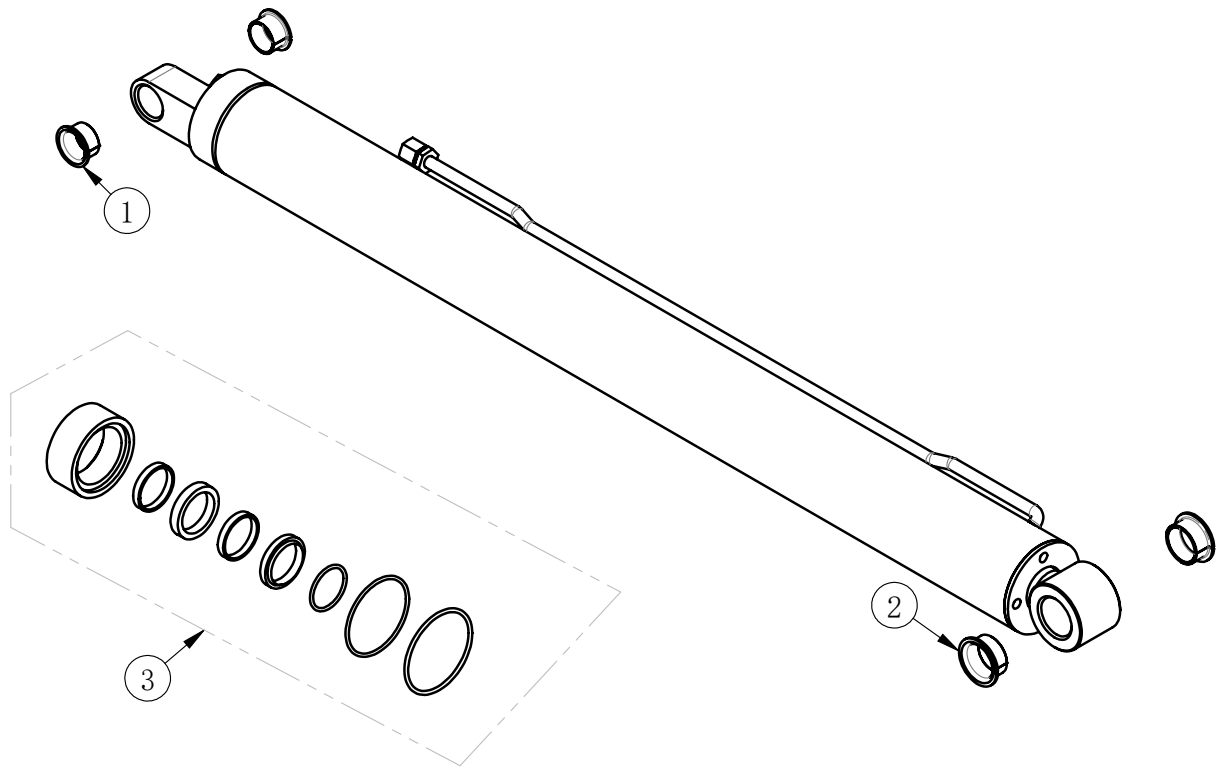

ITEM	DRAWNO	Description.	QT. Y
1	SF-1-25165	Self-Lubricating Bushing	2
2	SF-1-30160	Self-Lubricating Bushing	2
3	J401-1118000	Cylinder seal package	1
3.1	J401-1110003	Dustproof ring	1
3.2	J401-1110004	Wear ring	2
3.3	J401-1110005	Type U circle	1
3.4	J401-1110006	Combined seal ring	1
3.5	GB3452.1-35x2.65	o-ring	1
3.6	GB3452.1-65x2.65	o-ring	1
3.7	GB3452.1-75x3.1	o-ring	1

J401-1120000.

Revision A-03

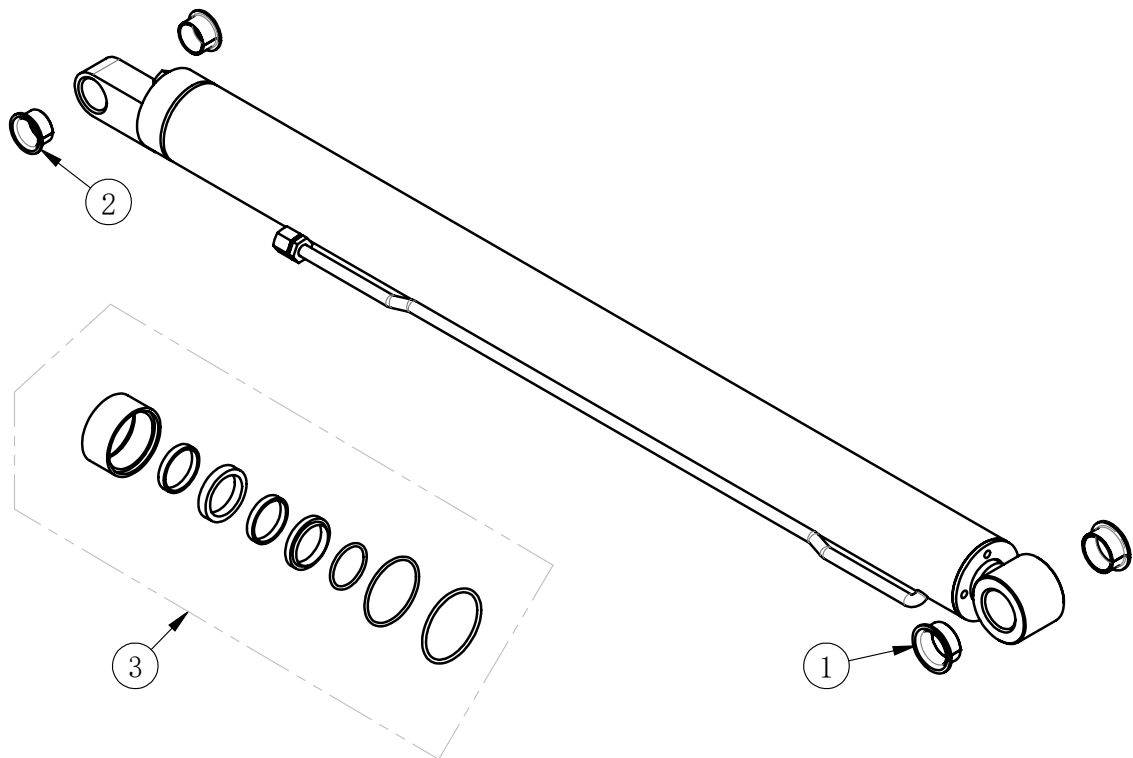

Pos.	DRAWNO	Description.	Qt.
1	SF-1-30160	Self-Lubricating Bushing	2
2	SF-1-25165	Self-Lubricating Bushing	2
3	J401-1119000	Cylinder seal package	1
3.1	J401-1110003	Dustproof ring	1
3.2	J401-1110004	Wear ring	2
3.3	J401-1110005	Type U circle	1
3.4	J401-1120006	Combined seal ring	1
3.5	GB3452.1-35x2.65	o-ring	1
3.6	GB3452.1-55x2.65	o-ring	1
3.7	GB3452.1-65x3.1	o-ring	1

J401-1320000.

Revision A-03

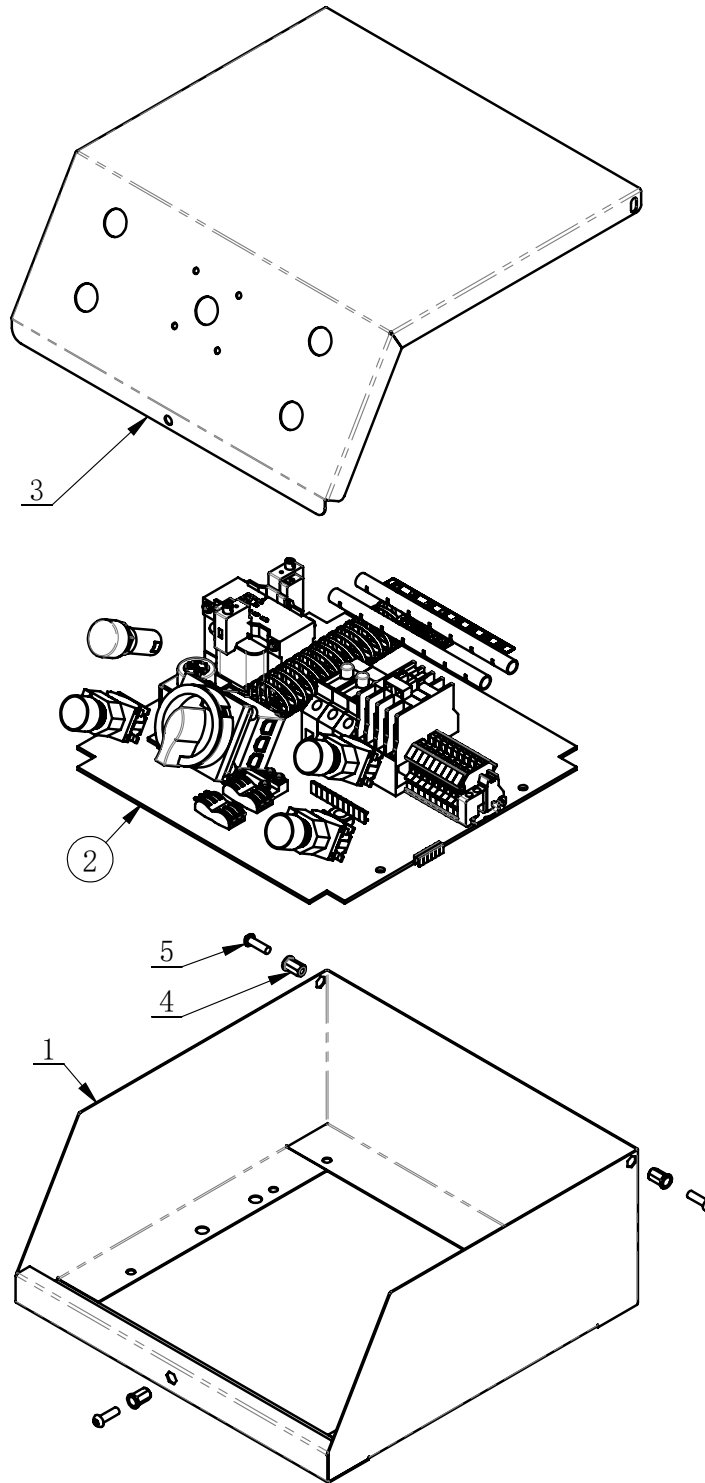

ITEM	PART. No	DESCRIPTION	QT. Y
1	J401-1321000	Controll Box Head	1
2	J401-1322000	Electro Plate	1
3	J401-1320001	Head Cover	1
4	GB17880.5-M6×15	FLAT HEXA RIVETTED NUT	3
5	GB70.2-M6×20	INNER HEXA CYLINDRICAL ROUND HEAD SCREW	3

J401-1322000.

Revision A-03

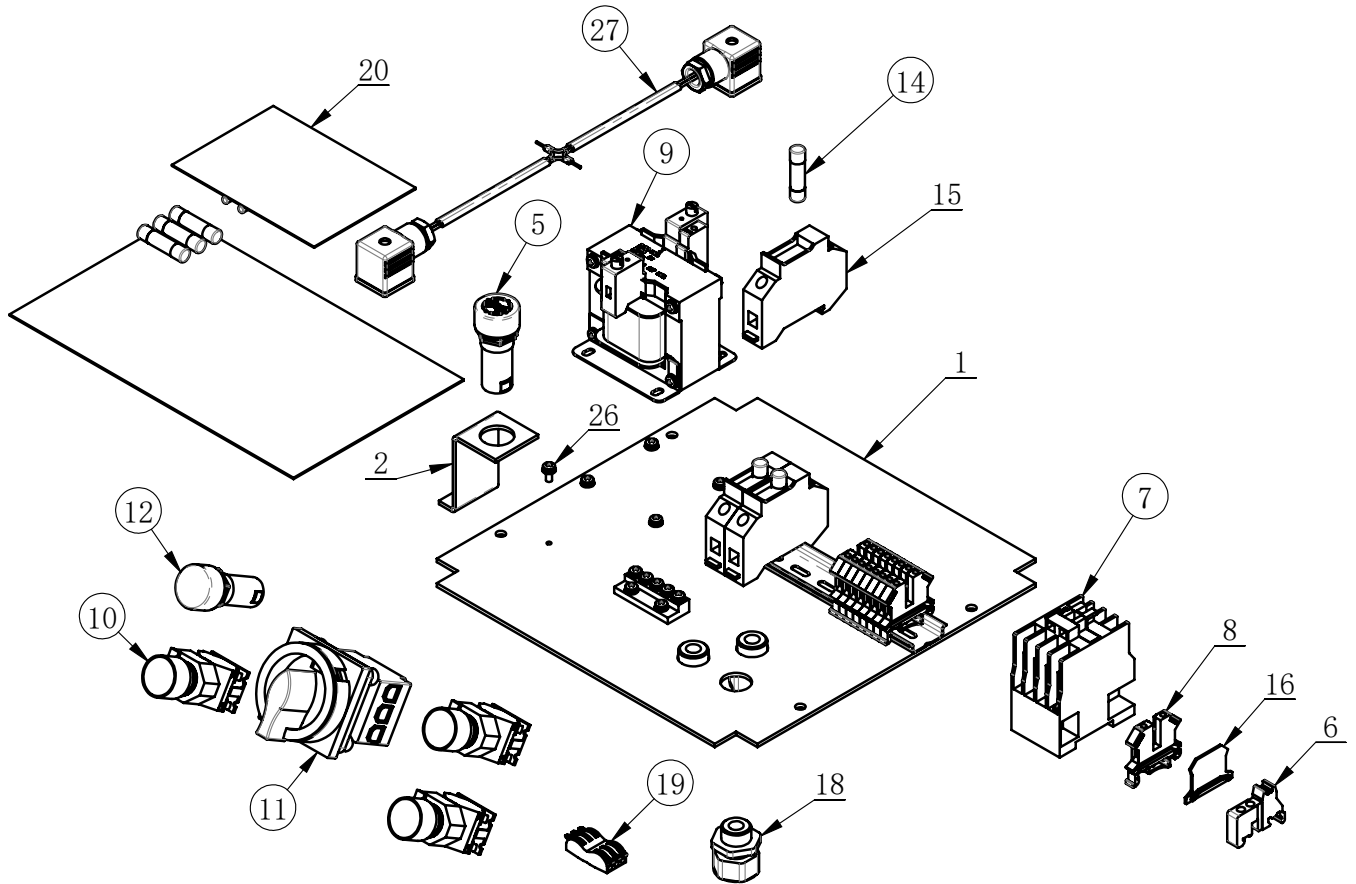

J401-1322000 (400V/3P)			
ITEM	PART.No	DESCRIPTION	QT. Y
1	J401-1322001	Electro Plate	1
2	J401-1322002	Support	1
5	TC-E-7202408	Signal Swith	1
6	TC-E-5130000	Connector	2
7	TC-E-4280124	AC CONTACTOR	1
8	TC-E-5110025	Connector	9
9	TC-E-3640232	Transformer	1
10	TC-E-27A0200	Push Button	3
11	J101-1512500	Main Switch	1
12	TC-E-7202409	Light	1
14	TC-E-7101512	Fuse	3
15	TC-E-7128323	Fuse Holder	3
16	J401-1322004	Connector	1
18	TC-E-7700020	CABLE LOCK HEAD M20X1.5	3
19	TC-E-5SPL003	Cable Connector	1
20	J401-1322100	fuse	1
26	GB9074. 4-M4x10	Screw M4x10-H	14
27	J401-1322900	Solenoid valve line	1

J401-1322000-230V1P (230V/1P)			
7	TC-E-4220124	AC CONTACTOR	1
14	MF-01-8120003	Fuse	2

J401-1330000.

Revision A-03

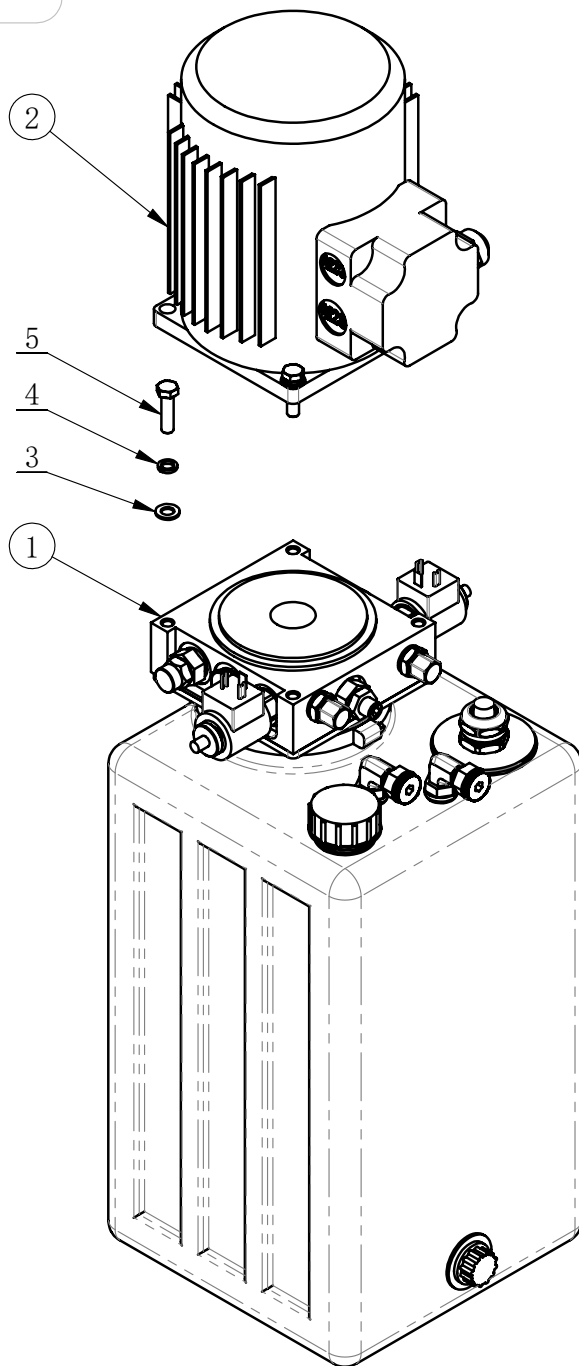

J401-1330000 (400V/3P)			
ITEM	PART.No	Description.	QT. Y
1	J401-1331000	Pump Unit	1
2	J101-1131000	Electro Motor	1
3	GB95-8	FLAT WASHER	4
4	GB93-8	STANDARD SPRING WASHER	4
5	GB5783-M8×30	HEXANGULAR BOLT	4

J401-1330000-220V50 (230V/50Hz/1P)			
ITEM	PART.No	Description.	QT. Y
1	J401-1331000-220V50	Pump Unit	1
2	J101-1501001	Electro Motor	1

J401-1330000-220V60 (230V/60Hz/1P)			
ITEM	PART.No	Description.	QT. Y
1	J401-1331000-220V50	Pump Unit	1
2	J101-1501002	Electro Motor	1

J401-1331000.

Revision A-03

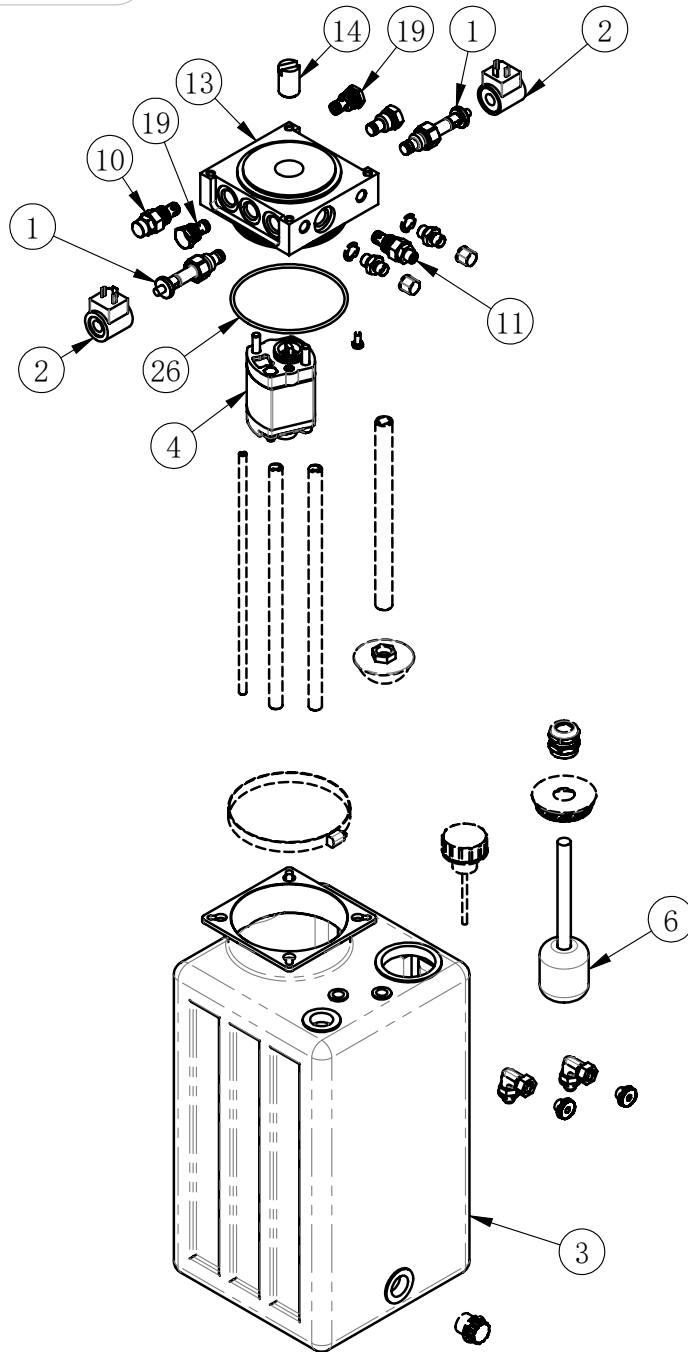

J401-1331000			
ITEM	PART. No	Description.	QT. Y
1	J401-1331002	Solenoid	2
2	J401-1331003	Coil 24V AC 18W	2
3	J401-1331006	Square fuel tank	1
4	J401-1331007	Gear pump	1
6	J401-1331009	Float level	1
10	J401-1331015	Relief valve	1
11	J401-1331016	Adjustable flow valve	1
13	J401-1331100	Valve plate	1
14	J101-1130101	Relief valve dumpener	1
19	TC-20-1031206	check valve ball type	2
26	UF2057	0 Seal ring $\phi 117*3.55$	1

J401-1331000-220V50			
4	J401-1331007-220	Gear pump	1

J401-1500000.

Revision A-01

Hydraulic connection diagram

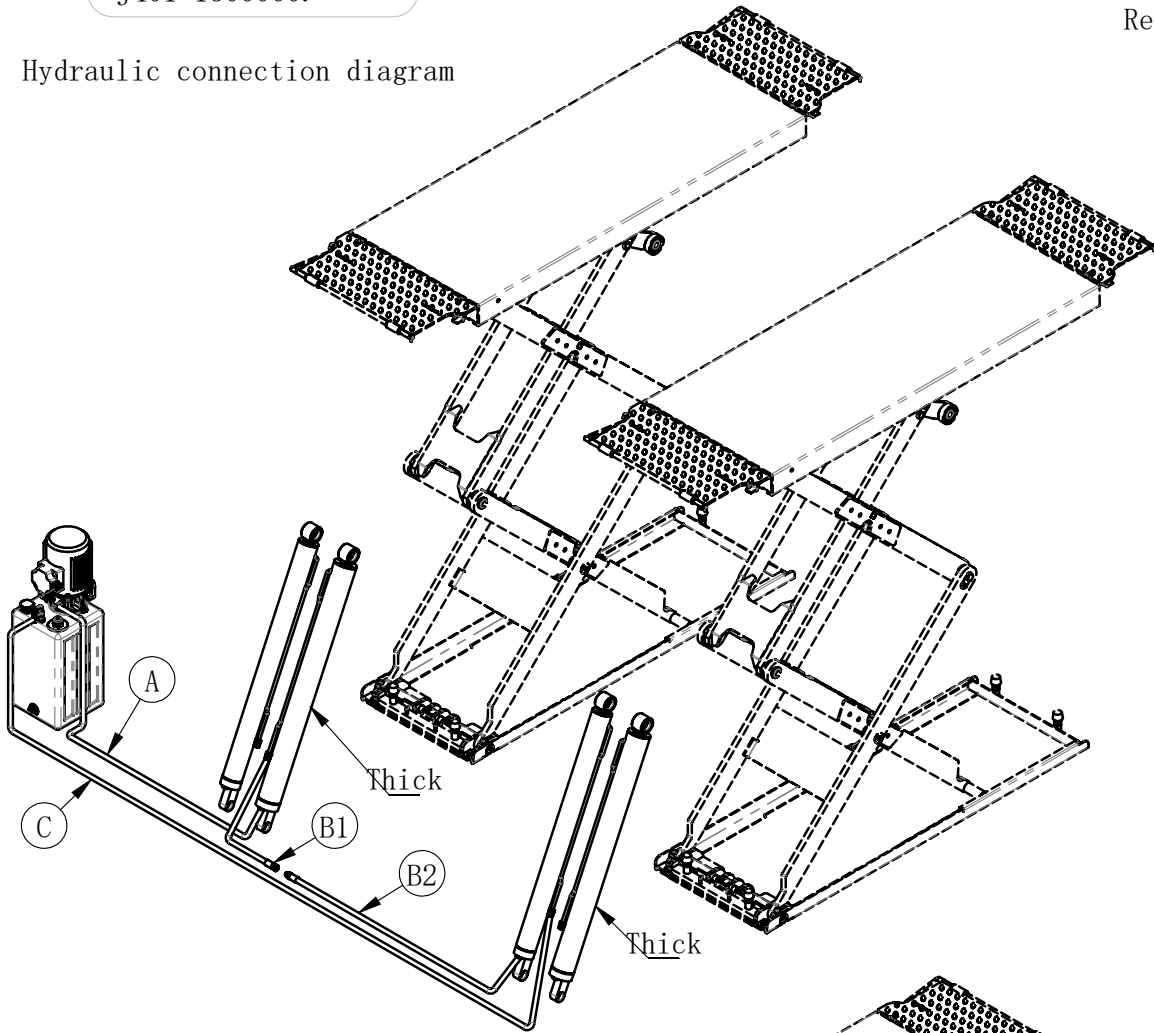

ITEM	PART. No	QT. Y
A	J401-1511000	1
B1	J401-1521000	1
B2	J401-1522000	1
C	J401-1531000	1
D	J401-1541000	1
E2	J401-1551000	1
E1	J401-1521000	1
F	J401-1561000	1

